

## STREAM

### Installation, Operation, and Maintenance Manual



## Table of Contents

<b>Introduction</b> .....	1
<b>General</b> .....	1
<b>Product Overview</b> .....	1
<b>Technical Specifications</b> .....	2
<b>Getting Started with STREAM</b> .....	5
<b>System Components</b> .....	5
<b>Dimensions</b> .....	6
<b>Mechanical Installation (Rectangular Ducts)</b> .....	6
<b>Probe Installation Steps</b> .....	6
<b>Probe Cover Installation Steps</b> .....	8
<b>Transmitter Installation Steps</b> .....	10
<b>Probe Modification</b> .....	10
<b>Electrical Installation</b> .....	11
<b>Electrical Input/Output Diagram</b> .....	11
<b>Electrical Connection Guide</b> .....	12
<b>Transmitter Wiring</b> .....	13
<b>Scout Diagnostics and Configuration App</b> .....	14
<b>Downloading the App</b> .....	14
<b>Default STREAM Settings</b> .....	14
<b>Commissioning and Adjusting Settings</b> .....	15
<b>Buttons in the App</b> .....	17
<b>BACnet Setup</b> .....	19
<b>What is BACnet?</b> .....	19
<b>Configuring BACnet</b> .....	19
<b>Default BACnet Settings</b> .....	19
<b>BACnet Points</b> .....	19
<b>Physical Connection – BACnet MS/TP</b> .....	20
<b>Physical Connection – BACnet/IP</b> .....	20
<b>Using STREAM</b> .....	21
<b>Getting Readings</b> .....	21
<b>LED Indicators</b> .....	21
<b>Maintenance</b> .....	22
<b>Troubleshooting</b> .....	22

<b>Replacement Parts .....</b>	<b>22</b>
<b>Technical Support.....</b>	<b>22</b>

## Introduction

### General

In this manual, you will find information regarding:

- *STREAM* specifications
- How to install *STREAM*
- The Scout Diagnostics and Configuration app
- Troubleshooting

### Product Overview

*STREAM* provides accurate sensing for airflow, air velocity, and temperature.

Some of its key features include:

- Isolated outputs
- BACnet MS/TP and BACnet/IP configurability
- Various wireless options
- Field configurability through a Bluetooth or desktop app
- Optional display
- Easy installation, ease of use, and minimal maintenance



This mark indicates an important point for the proper function of this product. Improper setup may cause unit failure. Pay close attention to all caution points throughout this manual.

For local area support, please contact your local Scout Technologies Representative.

For more information, visit [ScoutTechnologies.com](https://www.scouttechnologies.com)

## Technical Specifications

Transmitter	
<b>Environment (Operating)</b>	-30°C to 70°C (-22°F to 158°F) 0% to 95% R.H. (non-condensing)
<b>Input Power</b>	24 VAC ± 10% Class 2 50/60 Hz 19 VA max, 16 Sensors (2.2 VA, transmitter only)  <i>or</i> 24 VDC (18 – 32 VDC) 550 mA max, 16 Sensors (32 mA, transmitter only)
<b>Inputs</b>	2 universal inputs - Binary (contact closure or active) - Voltage (0 – 10 VDC) - Resistive (0 – 50 kΩ)
<b>Outputs</b>	4 analog outputs (10 mA max) - Voltage (0 – 10 VDC, configurable)
<b>BAS Communication</b>	BACnet MS/TP (9600, 19 200, 38 400, 76 800 baud rates) BACnet IP
<b>Configuration Communication</b>	Bluetooth USB-C
<b>Indicators</b>	Status LED bar Android/iOS/desktop app for diagnostics and configuration LCD display (optional)
<b>Housing</b>	UL 94 V-0, PC-ABS plastic
<b>Standards</b>	BTL (B-ASC) CE Cert. to CSA E60730-1 Conforms to UL Std. 60730-1 Cert. to CSA E60730-2-9 Conforms to UL Std. 60730-2-9 FCC/IC

Velocity/Temperature Sensor	
<b>Environment (Operating)</b>	-40°C to 85°C (-40°F to 185°F) 0% to 100% R.H. (non-condensing)
<b>Input Power</b>	Supplied by transmitter
<b>Sensor Type</b>	Thermal dispersion
<b>Sensor Thermistor</b>	Glass encapsulated, hermetically sealed
<b>Velocity</b>	Individual sensor: 0-5000 FPM, 2% of reading System accuracy depends on installation characteristics, please see Scout's application guides for more information
<b>Temperature</b>	±0.2°C (0.36°F), across operating range
<b>Housing</b>	Polypropylene 10% glass-filled plastic
<b>Standards</b>	CE Conforms to UL Std. 2043 Certified to ULC S142 FCC/IC

Probe	
<b>Housing</b>	Anodized (Type II) 6063-T6 aluminum
<b>Mounting Options</b>	Inside square/rectangular duct Outside square/rectangular duct Outside round duct
<b>Standards</b>	Conforms to UL Std. 2043 Certified to ULC S142



**NOTE:** This equipment has been tested and found to comply with the limits for a Class A digital device, pursuant to part 15 of the FCC Rules. These limits are designed to provide reasonable protection

against harmful interference when the equipment is operated in a commercial environment. This equipment generates, uses, and can radiate radio frequency energy and, if not installed and used in accordance with the instruction manual, may cause harmful interference to radio communications. Operation of this equipment in a residential area is likely to cause harmful interference in which case the user will be required to correct the interference at the user's own expense.

## Getting Started with STREAM System Components



Component	Description
<b>STREAM Transmitter</b>	The transmitter for the <i>STREAM</i> system.
<b>Mounting hardware</b>	Screws to mount the transmitter.



Component	Description
<b>STREAM Probe Cover</b>	The number of probe covers that correspond to your duct-insertion probes.
<b>Mounting hardware</b>	Fasteners to mount the probe cover to the probe.

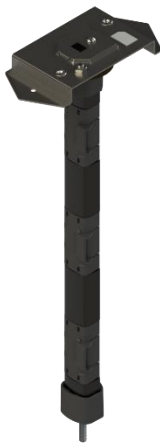

Component	Description
<b>STREAM Probe</b>	The duct-insertion probes corresponding to your configuration.
<b>Mounting hardware sets</b>	Fasteners to mount the probe to the duct.

## Dimensions

Please refer to the *STREAM* submittal at [ScoutTechnologies.com](http://ScoutTechnologies.com).

## Mechanical Installation (Rectangular Ducts)



Do not apply power to *STREAM* until the whole system has been properly installed. Applying power early can damage *STREAM*. Follow all steps outlined in this document.

### Probe Installation Steps

- STEP 1** Probes should be installed according to the spacing below. Mark a straight line across the width of the duct on the top side and mark locations for each probe.
- STEP 2** Mark locations for each probe on the bottom of the duct as well, ensuring the locations match the top-side locations such that the probes will be perpendicular to the top and bottom surfaces when installed.

**Probe Spacing**

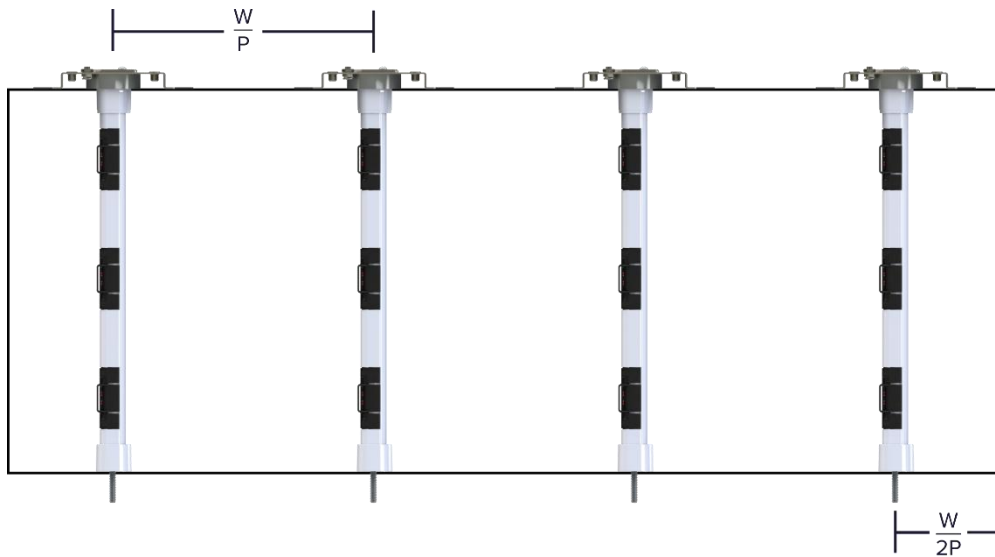

P = number of probes  
W = width of duct

**STEP 3** At each location marked on the top side for a probe, cut a 1.5 in. circular hole.

**STEP 4** At each of the locations marked on the bottom, cut a 0.5 in. circular hole.

## CAUTION ▼

The hole on the top of the duct **must** have a 1.5 in. diameter for the probe to fit through it. The 1.5 in. hole may need to be cut using a hole saw if a stepper bit of this size is not available.

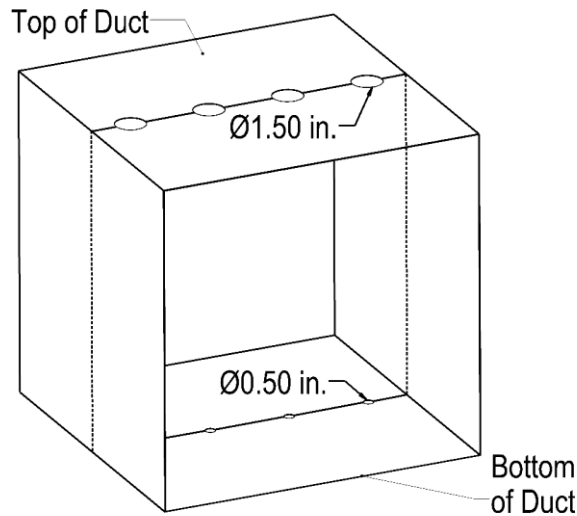

**STEP 5** Insert the probe through one of the 1.5 in. holes, ensuring the stud at the bottom of the probe is inserted into the corresponding 0.5 in. hole.

## CAUTION ▼

The probe length is correct if the stud extends fully out of the bottom of the duct when the mounting bracket is resting on the top surface of the duct. If there is a mismatch of fewer than 5 cm [2 in.], please refer to the [Probe Modification](#) section below.

**STEP 6** Align the pointed portions of the mounting bracket with the line marked on the duct earlier. Ensure the airflow label is pointed in the correct direction.

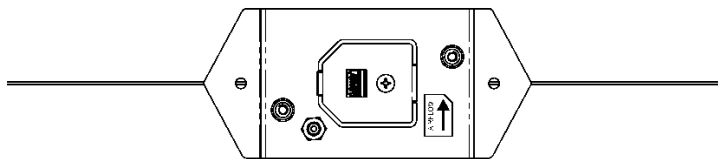

**STEP 7** Fasten the mounting bracket in this alignment using the sheet metal screws provided.

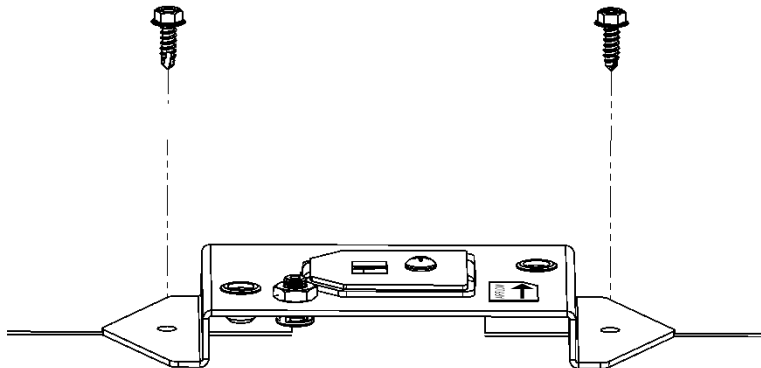

**STEP 8** Use the provided lock nut and gasketed washer to affix the bottom of the probe to the other side of the duct.

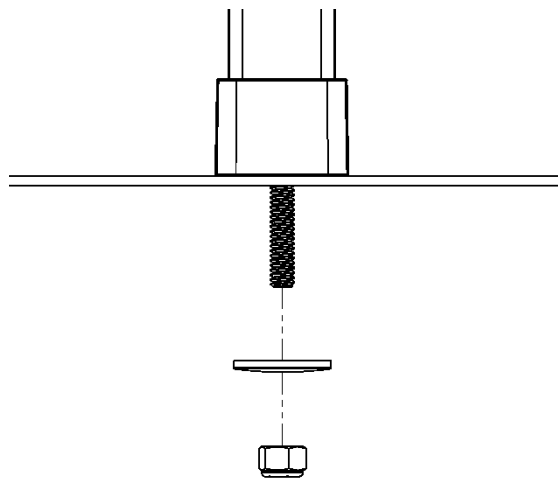

**STEP 9** For each probe, repeat Steps 5 through 8.

### Probe Cover Installation Steps

**STEP 1** Identify the probe cover that has cable only coming out from one side. Take this to the probe that will be furthest from the transmitter.

**STEP 2** Plug the ribbon cable that protrudes from the top of the probe to the connector in the probe cover labelled, 'Probe', as per the diagram below.

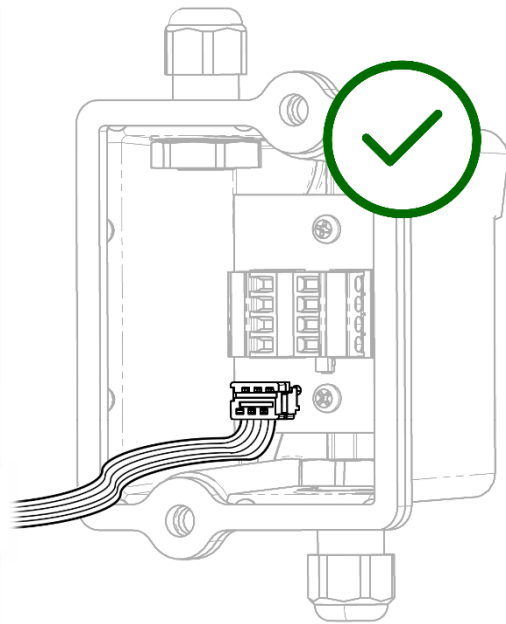
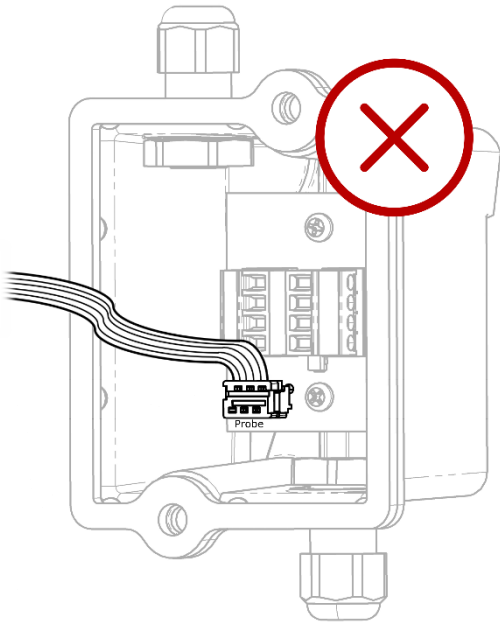

## CAUTION ▾

Incorrectly connecting the ribbon cable will result in improper performance of the system and may damage components. Take note of the installation images.

- STEP 3** Fasten the probe cover to the mounting bracket by using the provided fasteners. Ensure the airflow direction label on the mounting bracket matches the direction of the labels on the probe cover.

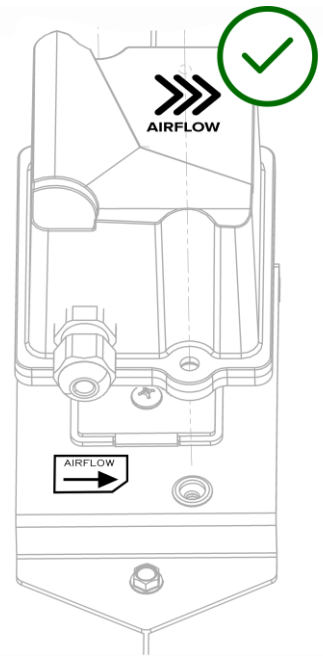
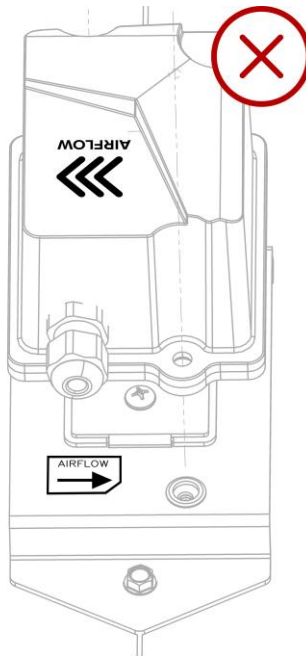
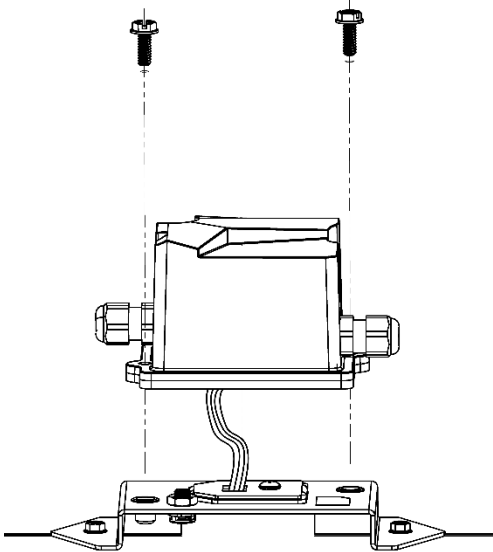

- STEP 4** Repeat Steps 2 and 3 for each probe cover. The last probe cover you connect should have a 25 ft. length of plenum cable connected to one cable gland. This cable will be wired to the transmitter later.

### Transmitter Installation Steps

- STEP 1** Remove the cover of the transmitter.
- STEP 2** Fasten the transmitter to a flat surface using hardware provided through the holes in the corners of the transmitter enclosure.



Ensure the transmitter will not be exposed to rain, moisture or inclement weather and is not installed in a plenum space.

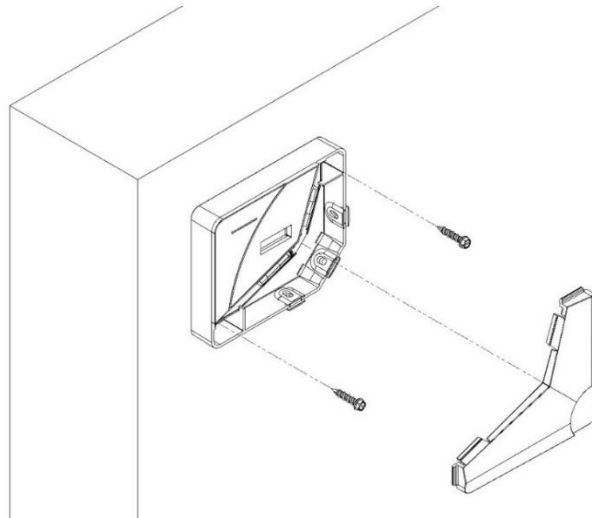

- STEP 3** Replace the cover on the transmitter after fastening.

### Probe Modification

Contact your local Scout Technologies Representative for instructions regarding modifying the probes if modification is required.

## Electrical Installation

### Electrical Input/Output Diagram

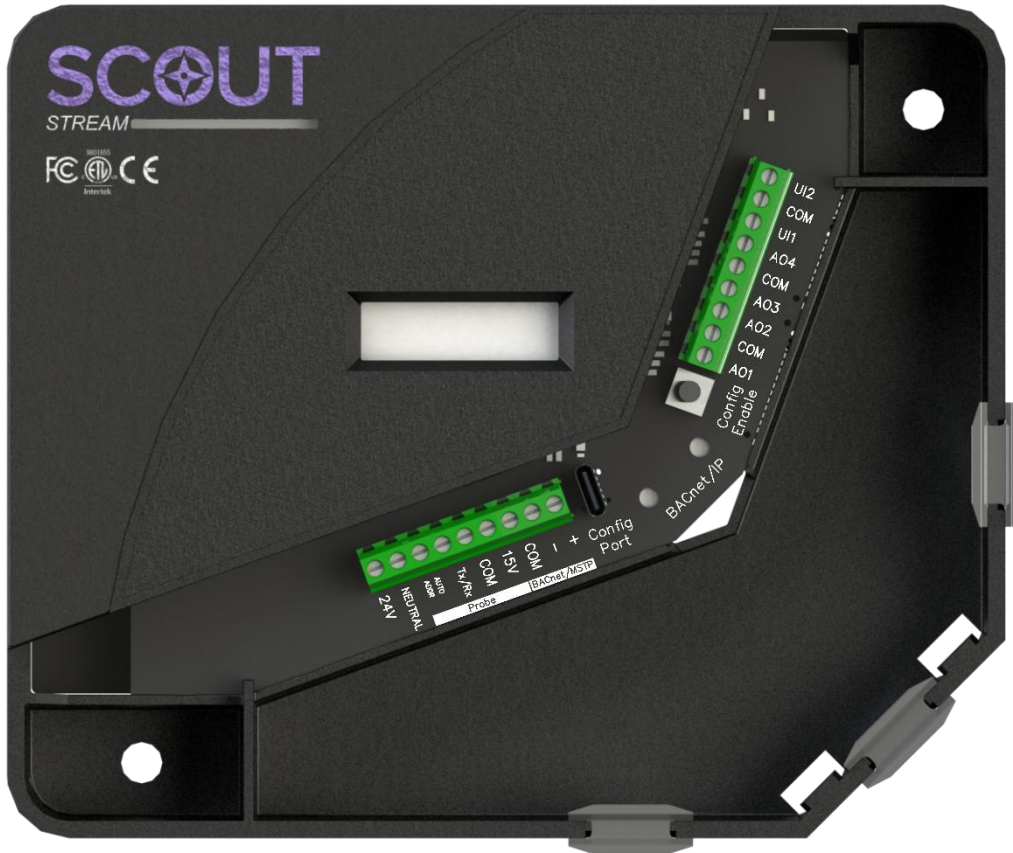

### NOTES:

1. All wire connections to the PCB terminal blocks must be 16 – 22 AWG.
2. Current and voltage drop should be considered when selecting wire gauge
3. Power is isolated from other inputs and outputs. NEUTRAL is not internally connected to COM.

## Electrical Connection Guide

Name	Input or Output	Description	Item to Connect
<b>24V</b>	Input	Isolated input power, hot (AC/DC)	16 – 22 AWG wire
<b>NEUTRAL</b>	Input	Isolated input power, ground	16 – 22 AWG wire
<b>AUTO ADDR</b>	Output	Sensor addressing line	16 – 22 AWG wire
<b>Tx/Rx</b>	Input/Output	Sensor data communication line	16 – 22 AWG wire
<b>COM</b>	Output	Output ground	16 – 22 AWG wire
<b>15V</b>	Output	Sensor power	16 – 22 AWG wire
–	Input/Output	BACnet MS/TP Negative Terminal	16 – 22 AWG wire
+	Input/Output	BACnet MS/TP Positive Terminal	16 – 22 AWG wire
<b>Config Port</b>	Input	Wired configuration interface	USB-C data cable
<b>BACnet/IP</b>	Input/Output	Port to communicate over BACnet/IP	Ethernet cable (CAT5 or better)
<b>Config Enable</b>	Input	Button to enable Bluetooth configuration	—
<b>AO1</b>	Output	Analog output	16 – 22 AWG wire
<b>AO2</b>	Output	Analog output	16 – 22 AWG wire
<b>AO3</b>	Output	Analog output	16 – 22 AWG wire
<b>AO4</b>	Output	Analog output	16 – 22 AWG wire
<b>UI1</b>	Input	Universal input	16 – 22 AWG wire
<b>UI2</b>	Input	Universal input	16 – 22 AWG wire



### CAUTION ▼

Review the product submittal for further information on power ratings and requirements.

## Transmitter Wiring

- STEP 1** Remove the cover of the transmitter.
- STEP 2** Locate the 25-foot length of plenum cable that is already attached to the probe cover nearest to the transmitter and wire it to the transmitter as per the color-coding in the diagram below.

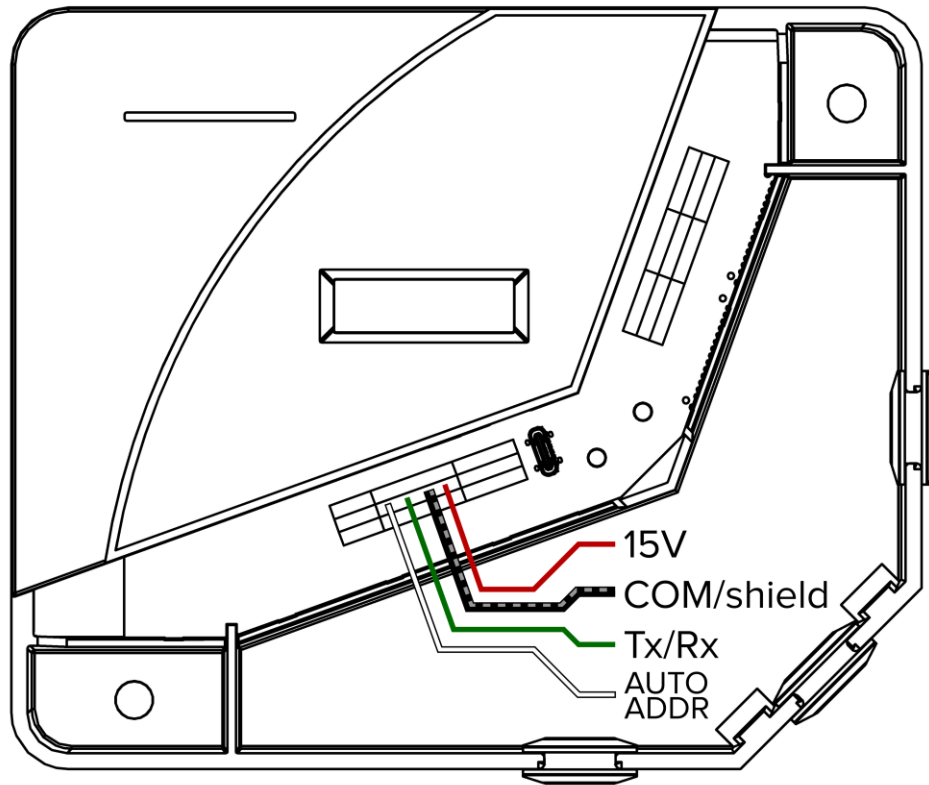

**NOTE:** If the cable is not long enough, it can be replaced with a plenum cable of the appropriate length and wire gauge.

- STEP 3** Wire any other supported communications to the transmitter.
- STEP 4** Wire power to the transmitter. See specifications for ratings and requirements.
- STEP 5** Replace the cover on the transmitter after fastening.

## Scout Diagnostics and Configuration App

### Downloading the App

The Scout app is used for commissioning and monitoring *STREAM*. The Scout app can be downloaded on iOS or Android via the Apple Store or Google Play Store, respectively.

**For mobile devices**, tap the appropriate button below or scan the QR code with your phone.



**For desktop**, the Scout app can also be downloaded from our website at [ScoutTechnologies.com/app](https://ScoutTechnologies.com/app).

For more details on how to use the app, see the section on **Commissioning and Adjusting Settings**.

### Default *STREAM* Settings



All *STREAM* transmitters come with the following default settings:

Name	Setting
Device Name	Scout STREAM
Description	
Duct Shape	Rectangular
Duct Width	0
Duct Height	0
Alarm Type	Off
Filter Time	1000 ms
Flow Type	Standard Flow
Unit Selection	Imperial
Velocity Scale	1
Velocity Offset	0 sfp

<b>AO1 Category</b>	Velocity
<b>AO1 Minimum Value</b>	0 sfpm
<b>AO1 Maximum Value</b>	5000 sfpm
<b>AO1 Minimum Voltage</b>	2 V
<b>AO1 Maximum Voltage</b>	10 V
<b>AO2 Category</b>	Temperature
<b>AO2 Minimum Value</b>	-40°F
<b>AO2 Maximum Value</b>	+122°F
<b>AO2 Minimum Voltage</b>	2 V
<b>AO2 Maximum Voltage</b>	10 V
<b>AO3 Category</b>	Off
<b>AO4 Category</b>	Off
<b>BACnet Config</b>	See the section on <a href="#">Default BACnet Settings</a>

## Commissioning and Adjusting Settings

Any of *STREAM*'s settings can be adjusted via the app, as in the instructions below.

- STEP 1** Download and open the Scout Diagnostics and Configuration App (see the section on [Downloading the App](#)).
- STEP 2** Use the CONTINUE button to proceed.
- STEP 3** On the Devices page of the app, nearby Scout devices should appear automatically when using Bluetooth, as below. If the transmitter does not appear or no devices are detected, use the  button to search again for nearby devices. When connecting with the desktop app via USB-C, devices will not appear until the  button has been used.

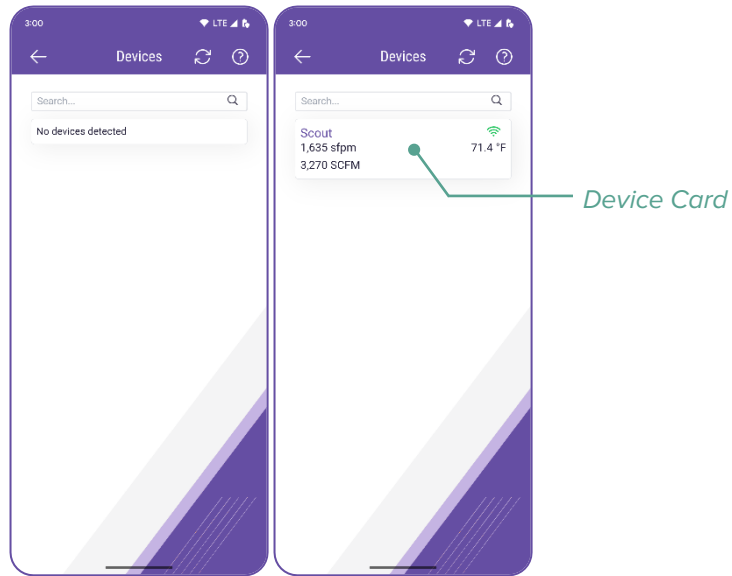

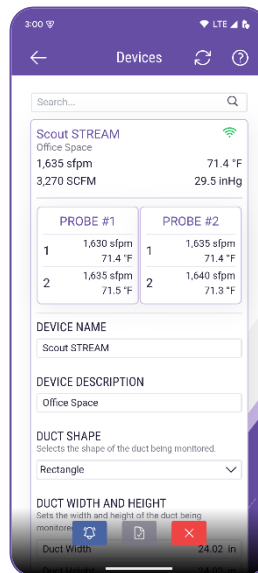

**STEP 4** Tap or click on the Device Card for the transmitter needing settings changes. To confirm this is the right transmitter, press the  button, found at the bottom of the card. This will cause the LED on the transmitter to pulse in a different color. Press the button again to return the LED to its normal operating color.

**STEP 5** When connecting via Bluetooth, the settings can be edited after pushing the Config Enable button on the transmitter itself. When connecting via the USB-C configuration port, configurability will already be unlocked.



**STEP 6** Tap or click in the box to adjust a setting. Some settings accept alphanumeric input or only numeric input, while others have a selection menu.

**STEP 7** Use the  button to save the new settings. When all changes are saved, the button will change to a gray color ().

**STEP 8** Use the  button to collapse the Device Card.



**NOTE:** For more information on the buttons in the app, refer to the section on [Buttons in the App](#).

## CAUTION ▼







Ensure your settings match your physical duct parameters (size and shape) and that your BACnet settings match your needs.

### Buttons in the App

The app has several buttons that are accessible on various pages of the app:

Button	Function
	Returns to the previous page of the app.
	Opens up help options, including documentation, such as submittals and the Installation, Maintenance, and Operation (IOM) manual.
	Refreshes the device list, searching again for nearby Scout devices to display. Tap or click if a device is not showing up.

The app also has several buttons that are applicable to a single device when connected to it:

Button	Function
	<p>Pings the transmitter, causing the LED bar to pulse teal. Tap again to stop pinging.</p>
	<p>Indicates that unsaved configuration changes exist. Tap to save changes. Turns gray if the configuration is saved.</p>
	<p>Closes this <i>STREAM</i> device's card. The device will still appear in your list of nearby devices.</p>
	<p>Starts an update on the transmitter. You will be guided through a series of prompts. Take care to read all prompts thoroughly. This button will only appear if an update is available.</p>
<p> <b>CAUTION</b> ▼</p>	
<p>When updating the transmitter over Bluetooth, do not disconnect from it, turn off your phone's Bluetooth, walk away, or turn the transmitter off. Any of these will result in a failed update and may result in unexpected behaviour. The DFU can be canceled if required.</p>	
	<p>Restarts the connected <i>STREAM</i> device. The device will disconnect from the app, power off and then power back on after a short delay.</p>

## BACnet Setup

### What is BACnet?

BACnet MS/TP and BACnet/IP are two versions of a building automation communication protocol that can be used for communication between *STREAM* and the building automation network. BACnet communication allows the end user to verify airflow, air velocity and temperature in ducts as expected. The user can also set up alarms or trends to monitor conditions.

### Configuring BACnet

When configuring *STREAM*, the user needs to assign the unique BACnet Instance Number for the device.

On any BACnet MS/TP network:

- MAC Address can be between 0 and 127 and must be unique to the MS/TP segment.
- BACnet Instance Number can be between 0 and 4 194 303 and must be unique to the network.
- Baud Rate can be 9600, 19 200, 38 400 or 76 800 and must match that of the Router/System Controller for the MS/TP segment.

On any BACnet IP network:

- BACnet Instance Number can be between 0 and 4 194 303 and must be unique to the network.
- DHCP may need to be disabled on some networks. If so, a unique static IP, the correct subnet mask, and the correct gateway will need to be set.

**NOTE:** All *STREAM* transmitters can be configured for BACnet IP or MS/TP, though the system must be rebooted after changing between modes.

### Default BACnet Settings

All *STREAM* transmitters come with the following default BACnet settings:

Name		Setting
Mode		BACnet/IP
Instance Number		0
BACnet/IP Config	UDP Port	BAC0
	Foreign Mode	Disabled
IP Config	DHCP	Enabled

### BACnet Points

See the *STREAM* Product Submittal at [ScoutTechnologies.com](http://ScoutTechnologies.com) for the BACnet Points List.

### Physical Connection – BACnet MS/TP

BACnet MS/TP consists of a three-wire network architecture. Daisy chain the +, –, and COM connections of all devices on the network segment.

A BACnet MS/TP segment has a limit of:

- Maximum of 32 devices
- Maximum length of 320 m (1050 ft.) for the whole segment

When using shielded cable, ground the shield at one end of the network segment only. Connect the shield of the cable entering a device to that of the cable exiting the device.

Remove the termination resistor or disable any network terminations on all devices when adding devices to an existing network segment. Terminate the MS/TP network segment at each end of the network segment by connecting a 120 $\Omega$  resistor between the + and – terminals.

### Physical Connection – BACnet/IP

Connect an Ethernet cable between the BACnet/IP port on the transmitter and an IP network via an Ethernet switch, router, or other method. The IP network should be the network where you want to access *STREAM*'s data.

## Using STREAM

### Getting Readings

STREAM’s airflow and temperature readings can be reported via BACnet MS/TP, BACnet IP or the analog outputs. The Scout Diagnostics and Configuration app and the optional display also provide live updates of the readings, which can be visually read for immediate assessment.

### LED Indicators

STREAM has a status LED bar with different indicators as follow:

LED State	Condition
Steady Purple	Normal operation
Pulsing Teal	Subject to pinging operation
Flashing Red	Alarm state

**NOTE:** If the LED has a different light pattern than the listed options, contact your local Scout Technologies Representative.

## Maintenance Troubleshooting

Symptom	Possible Causes	Solutions
<b>STREAM does not turn on</b>	Voltage is not within operating range	Check the voltage being supplied to the <i>STREAM</i> transmitter and ensure it falls within the ranges specified in the <b>Technical Specifications</b> .
<b>No sensor readings</b>	Incorrect wiring	Ensure the wiring to the transmitter's Probe terminals (15V, COM, Tx/Rx and AUTO ADDR) matches the <b>Transmitter Wiring</b> instructions in this manual.
<b>Unexpected sensor readings</b>	Incorrect configuration	Connect to the transmitter via the Bluetooth app or the Config Port and ensure the configuration is correct.
	Incorrect probe installation	Verify that the probes have been installed in the correct orientation as per the guidelines in this manual.
<b>Degraded sensor readings</b>	Dirty sensors	Disconnect power to <i>STREAM</i> and remove debris from the sensors by wiping them or using compressed air. Reapply power to <i>STREAM</i> .

## Replacement Parts

Replacement parts are available. Please contact your local Scout Technologies Representative.

## Technical Support

If technical support is required, please contact us at [Support@ScoutTechnologies.com](mailto:Support@ScoutTechnologies.com).

Hours of Operation: Monday – Friday, 8:00 AM – 4:30 PM CT.

**NOTE:** If you require support after hours, please schedule with Scout Technologies 48 hours in advance.